

Manual instruction

*Instruction number:
LMI-14-01/09/06/A*



Precision balances WPP series



**MANUFACTURER
OF ELECTRONIC WEIGHING INSTRUMENTS**

RADWAG 26 – 600 Radom, Bracka 28 Street, POLAND
phone +48 48 38 48 800, phone/fax. +48 48 385 00 10
Sales Department +48 48 366 80 06
www.radwag.com

May 2007

Contents

1. SETTING UP THE BALANCE	5
1.1. WPP balances.....	5
2. APPLICATION	6
3. CONDITIONS OF APPROPRIATE USING	7
4. KEYBOARD	8
5. START AND SERVICE	9
6. WEIGHING	10
7. CALIBRATION	11
7.1. Balance with external calibration.....	12
7.2. Balance with internal calibration.....	13
7.2.1. Software set-up for calibration.....	15
7.2.1.1. Dependently on changes of temperature - parameter <AC_t>.....	15
7.2.1.2. According to time - parameter <AC_C>.....	16
8. SCHEDULE OF ENTERS IN SETTING FUNCTIONS	17
8.1. Summing function.....	18
8.2. Counting pieces.....	19
8.2. Control of deviations % according to standard mass.....	22
8.2.1. Standard mass defined by its weighing.....	22
8.2.2. Standard mass introduced to balance memory by user.....	23
8.3. Definition thickness of solids and liquids.....	24
8.3.1. Testing thickness solids.....	24
8.3.2. Testing thickness of liquid.....	24
9. Adjusting the balance to working conditions	25
9.1. Back light.....	26
9.2. Turn on/off autozero system.....	27
9.3. Calibration - settings.....	28
9.4. Choice of criteria of stable result depending on conditions of using.....	28
9.5. Average result of weighing.....	29
9.6. Adjusting scale for dosage procedures.....	30
9.7. Select default unit of weighing.....	31
10. FUNCTIONS FOR USING RS 232	32
10.1. Choice of speed of transmission.....	33
10.2. Definite send data as stable/not stable.....	34
10.3. Continuous work (RS 232).....	35
10.4. Set-up date as basic parameter of printout.....	36
10.5. Turning on and off marker of last digit on printouts.....	37
10.6. Automatic work for RS 232.....	38

11. COOPERATION WITH PRINTER OR COMPUTER.....	39
11.1. Schedules of connecting conductors	39
11.2. Printing data with date and time.....	40
11.3. Cooperation with statistic printout Kafka SQS	40
11.4. Format of sending data.....	40
12. Reports from scale	42
12.1. Current control of calibration fault	42
12.2. Report from calibration of scale	43
13. WEIGHING LOADS UNDER SCALE	44
14. LIST OF ORDERS COMPUTER – SCALE	44
15. ORDERS ON DIGITAL DISPLAY.....	45
16. TECHNICAL PARAMETERS	46
17. ADDITIONAL EQUIPMENT.....	47

1. SETTING UP THE BALANCE

1.1. WPP balances

Cut safety tape off. Take balance off the box. Take out balance from package. Take all necessary to correct performance of balance elements off the box.

Take off the pan and remove carrying protection, look at drawing below.

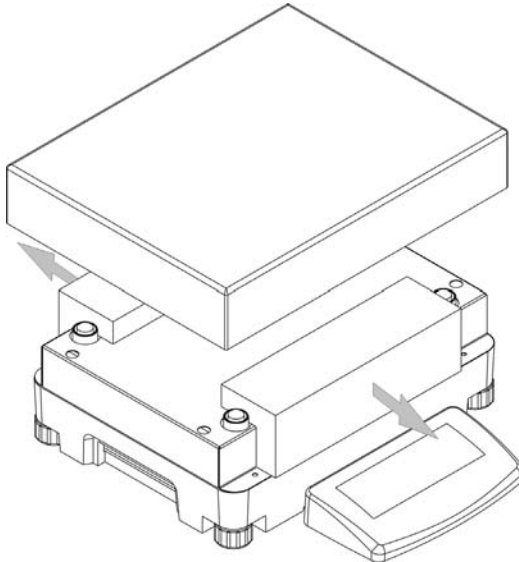

Placing balance in place of using.

2. APPLICATION

Electronic scale is appropriate for precise measurements mass in laboratory conditions with possibility of setting to zero in all measure range. Balance calibration is done by **CAL** on balance keyboard.

Functions accessible to user are divided into 4 parts:

- ✓ **Functions for weighing units (press Units key)**
 - Weighing in grams, Result with 3 places after dot,
 - Weighing in carats [ct],
 - Weighing in units from beyond **SI**: [GN], [mom], [oz], [dwt]. Access to these units is blocked from factory menu level.

- ✓ **Functions for calibration and weighing modes (ZERO/TARE key + Units key)**
 - Summing function
 - Counting pieces
 - Control of deviations % according to standard mass
 - Thickness of liquids
 - Thickness of solids

- ✓ **Choice of criteria of stable result depending on conditions of using (ZERO/TARE key + cal key)**
 - Back light function
 - Turn off/on system of autozero
 - Turn off / on automatic calibration in relation to changes of temperature
 - Turn off/ on automatic calibration in relation to time from last calibration
 - turn on/off marking of last digit in printout
 - Setting amount of average measurements
 - Average result of weighing
 - Adjusting balance for dosage procedure
 - Select default units of weighing

- ✓ **Function for using RS 232 (ZERO/TARE key + print key)**
 - Choose speed of transmission
 - Define sent data as: stable / not stable
 - Continuous work
 - Setting data as additional element of parameter in printouts
 - turn on/off marking of last digit in printout
 - automatic work for RS 232

Moreover balance can be used to weigh hang loads, print report of calibration, check deviation of calibration and print reports of testing thickness of liquids and solids.

3. CONDITIONS OF APPROPRIATE USING

- scales should be used and stored in rooms without vibrations and shakes, without drafts and dust
- temperature of air should be $15^{\circ}\text{C} \div +30^{\circ}\text{C}$ for WPP balances
- during using balances changes of temperature shouldn't be higher than $0,5^{\circ}\text{C}$ per one hour
- scales should be replaced on wall console or stable table, far from sources of heating
- strong magnet is installed inside of balance – so it's important to be careful during weighing magnetic materials. Use hang loads if it's possible not to expose magnetic load to magnet influence. Suspension is replaced on basic of the balance.
- If static electricity has influence on scale annunciators it's necessary to connect it to earth. Earth screw is replaced in back part of balance base.
- Scale should be replaced in horizontal level to assure precision of weighing

4. KEYBOARD

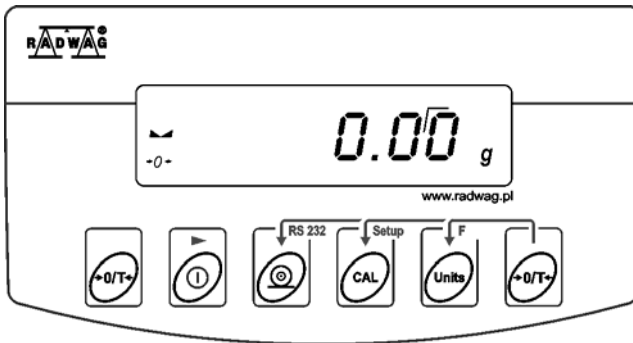

Key **ON/OFF** is to turn display off. Others subassemblies are still supplying and scale is in stage of waiting for further work. If user press this once again weighing stage with measure units are displayed.



PRINT key is to send current state of display to external mechanism by connector RS 232



CAL key is to calibrate. It's manual calibration. After press if scale starts calibration. There shouldn't be any load on scale. If you press **ZERO/TARE** during calibration stops and weighing returns



Units is function key. It's to choose measure unit (in which measurement is done) or to change some functions in user menu



ZERO/TARE key is to set indication to zero. After setting to zero indication is zero. If load is taken off scale display show its mass with "minus" sign. Setting to zero can be done in all measure range of scale

5. START AND SERVICE

Before supply is turn on glass of weighing chamber should be draw. Balance should be levelled. To level scale screw legs in order air bubble was in centre position.

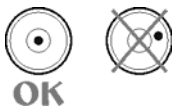

Time of heating for WPP series

If scales were in much lower temperature (f.eg. in winter) **time of acclimatization** and heating is 4 hours before connect to supply net. During warm stabilization of scale indications on display can change.

Correct work of balance is possible in temperature range given in technical parameters point 16. If balance is outside the temperature range of work, display will show pictogram (black triangle).

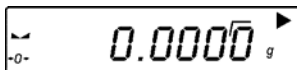

In such case temperature of balance work should be increased (by low temperature) or reduced if it's to high.

After time of warm stabilization press **ZERO/TARE** key – zero indication of mass appears on display. Balance is ready to weighing. If display doesn't show zero stage press **ZERO/TARE** once again.

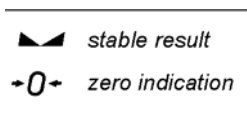

5.1. Legalized balance WPP /C/2

- Only following measure units can be used:
g, mg, ct
- It is not possible to change settings for automatic
 - Point 7.2.1. Software set-up for calibration
 - Point 9.2. Turn on/off autozero system
 - Point 10.2. Turn on and off marker of last digit on printouts
 - Point 10.5. Definite send data as stable/not stable

6. WEIGHING

Before weighing or if the conditions of work changes (f.eg. if temperature of surrounding is higher then 3°C for WPP balances) scale should be calibrated according to way in point 7.

- Scale should be load few times by mass close to max capacity before measurements
- Check if not load scale shows „precise zero” - **ZERO** if measurement is stable
- order **STAB**, if not press key **ZERO/TARE**,
- by means of **Units** key set measure unit



g, mg, ct, and if they are accessible in factory menu GN, mom, oz, dwt,

- put load on scale and read result on display

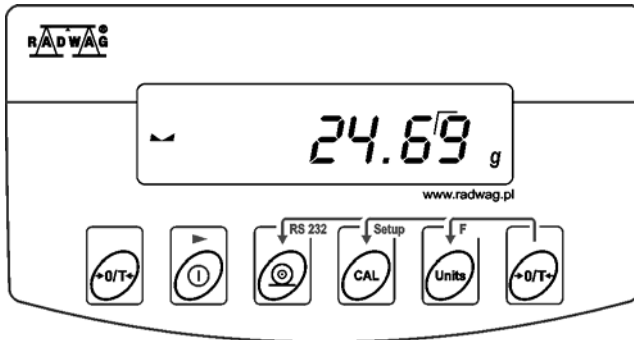

- indication can be setting to zero many times by pressing key **ZERO/TARE** (summary of mass loads record to scale memory cannot be bigger then its max capacity)



Don't turn off scale from supply power between following measurements. Turn scale off by key **ON / OFF**.
If user press key **ON/OFF** once again scale is ready to following measurements.

7. CALIBRATION

To assure very precise weighing introduce correction factor to balance memory – **it's calibration**. Scales have system of internal calibration (calibration mass with all automatic system is built inside of scale)

Balances can have:

- automatic internal calibration
calibration mass with automatic system is installed inside of balance
 - WPP /C/2 series

- external calibration
calibration is done by external weight
 - WPP /C/1 series
 - WPP /C/10 series

Calibration should be made if:

- we start weighing
- there are long breaks between following measurements
- temperature of surrounding changes not more than 3°C for WPS balances



During calibration platform of balance cannot be loaded.

If there is load on platform order **unLoad** appears on display. This is command to take load off platform.

Calibration can be stopped if it's necessary. To stop calibration press key **ZERO/TARE** after pressing key **CAL**

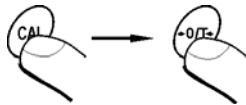

7.1. Balance with external calibration

Pressing key **CAL** causes calibration of balance



on display appears:

NO CAL

(balance starts autotest for calibration –during test you cannot load the scale), and then order

LOAD

(it is command to put calibration mass on scale) calibration mass is given in grams. If you the mass on scale on display appears

-- CAL --

calibration and then

UNLOAD

take calibration mass off scale. After taking calibration weight off scale, balance shows zero. If unsuitable load is put on scale – balance displays

CAL ER (calibration is cancelled)

7.2. Balance with internal calibration

Process of calibration can be started automatically or manually. Manual operation consists in pressing **CAL** key. System of automatic calibration will automatically perform calibration informing user about successive stages.

Cycle of automatic calibration proceeds as follows:

- balance software detects necessity of calibration and signalizes it by marker of Celsius degree or by black marker



- from this moment time of 5 minutes is counted in which weighings can be performed
- when this time elapses display indicates CAL_30 message and starts count down 30..29..28 do 0 (indicated value is the counter)



- user has 30 seconds to make a decision:
 - if calibration is to be performed, does not take any actions
 - if one wants to finish measurements presses **TARE** key, after its pressing balance returns to weighing showing previous result of weighing (possibility of finishing series of measurements) in 5 minutes balance will indicate CAL_30 message again
- process of calibration can be postponed frequently, but fact that long postponing of calibration can be cause of bigger error during weighing should be noticed. These errors are effect of changes of temperatures and as consequence changes of balance sensitivity

Automatic system includes 3 possibilities:

- **calibration after connection to power supply**
after about 15minuts from first connection to power supply balance makes calibration automatically
- **calibration with regard to changes of temperature**
balance is provided with precise system of controlling temperature changes, temperature of calibration is registered every time, next is started if temperature of surrounding changes 3°C for WPP balances



- **calibration with regard to passage of time**
user can declare 4 spaces of time that makes criterion for calibration, following option are accessible: calibration every 1 - 9 hours.



7.2.1. Software set-up for calibration

7.2.1.1. Dependently on changes of temperature - parameter <AC_t>

Press key **ZERO/TARE**. When horizontal lines appear on display press key **CAL**.

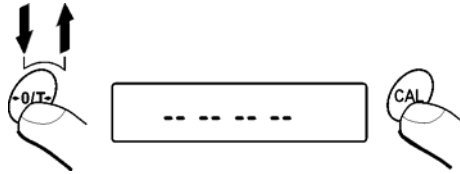

Press key **Units** many times until order **AC_t** appears on display.

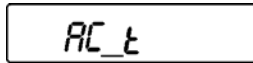

after press on key **PRINT** current set up for function appears

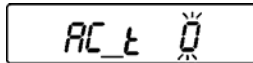

Press key **Units** and set value **AC_t** as 1 or 0
With regard to following dependences

- AC_t 0** – automatic calibration with regard to changes of temperature
- AC_t 1** – balance should be calibrated manually by pressing key **CAL**.

Confirm by pressing key **PRINT**

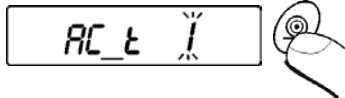

Attention:

Ac_t parameter is available only for not verified balances

7.2.1.2. According to time - parameter <AC_C>

Calibration is made after some time from last calibration (1- 9 hours of time). Press **ZERO/TARE** key. If there are horizontal lines on display press key **CAL**.



Press **Units** key until order **AC_c** appears on display.

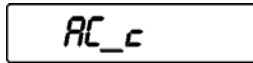

Press key **PRINT** – current set up for function is displayed. Press key **Units** and choose one of described values

- AC_C 0** – enter to declared time of calibration
- AC_C 1** – time calibration is turn off

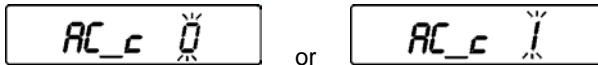

Confirm chosen value by key **PRINT**

After choosing function **AC_c 1** display shows name of following function After choose **AC_C 0** display show order:

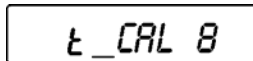

Press key **Units** many times and set value **t_CAL** as 0 or 1,2,3,4,5,6, 7,8,9 with regard to chosen digit means space of time every calibration is done.

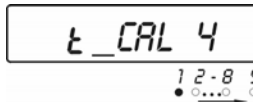

Confirm set up by pressing key **PRINT**

Attention:

Resignation from calibration by pressing key **ZERO/TARE** during calibration **Ac_c** parameter is available only for not verified balances

8. SCHEDULE OF ENTERS IN SETTING FUNCTIONS

- summing function (only WPP C/2 series)
- Counting pieces
- Control of deviations % according to standard mass
- Thickness of liquids
- Thickness of solids

Press **ZERO/TARE** key (scale shouldn't display STAB). If horizontal lines appears on display press key **Units**

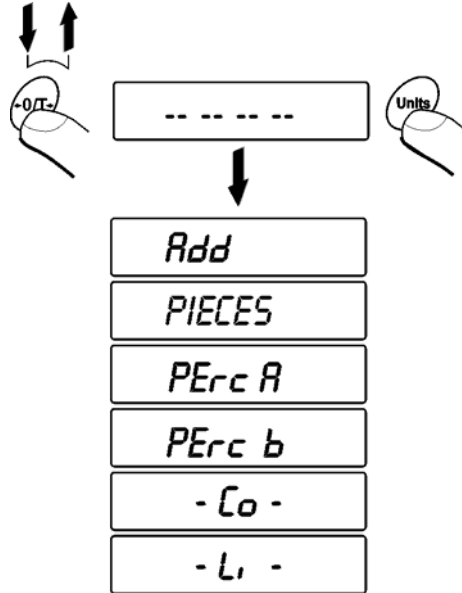

After pressing key **Units** name of first approachable function appears. Every next pressing key **Units** makes names of following approachable functions appear on display. Way of setting functions is described in further part of instruction.

8.1. Summing function

(only for WPP /C/2 series)

8.1.1. Activation of the function and procedure

In sum procedure following components are added in order to make mixture. After adding following component composition of the mixture is presented on the display. During sum procedure masses of the components are sent to joint RS 232 (printout on the printer or sending to computer application).

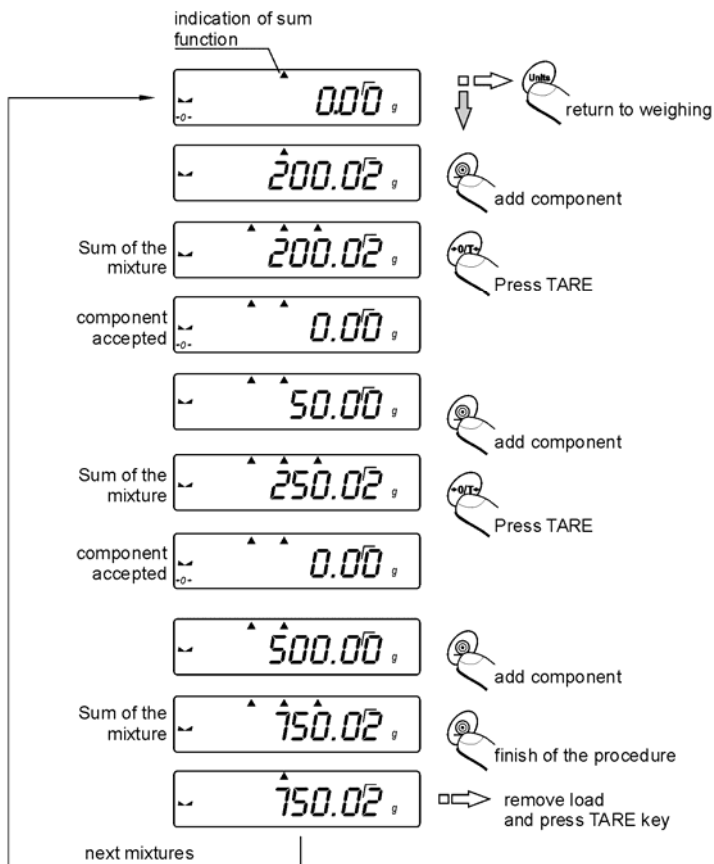
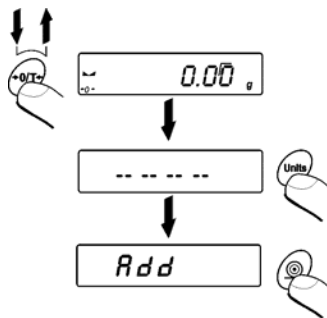

8.2. Counting pieces

Software's enables to amount small elements with the same mass To use this function:

- put package on scale and press **ZERO/TARE** key its mass to balance memory
- press key **ZERO/TARE**. When horizontal lines appear on display press key **Units**



- Press **Units** key – display appear



- Press **PRINT** key to activate function (you can select from 10, 20, 50pcs or free definable)

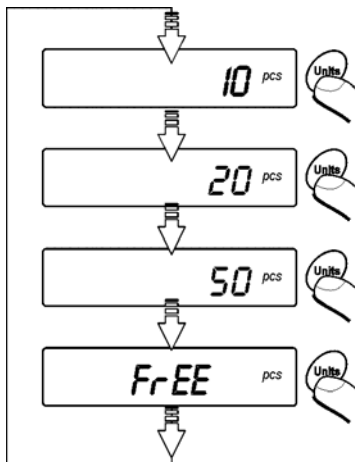

- Press **Units** key – choose value
- If you want to start the counting pieces function, please choose one of the values, eg. 20 pcs

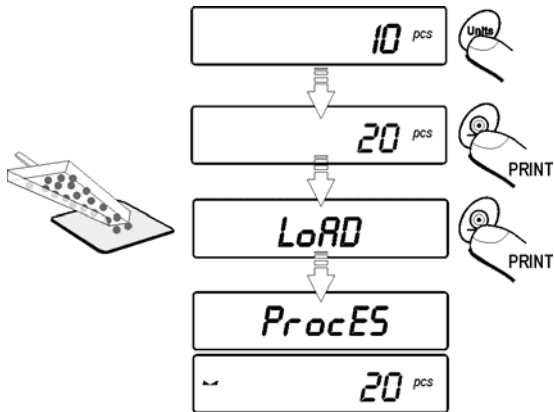

- After displaying of **LoAd** information, please put on the pan of the balance as many pieces as have been chosen (20pcs).
- If option Free was chosen, the display will show the number of pieces with flashing of the first digit – you should inscribe as many pieces are in the mass pattern

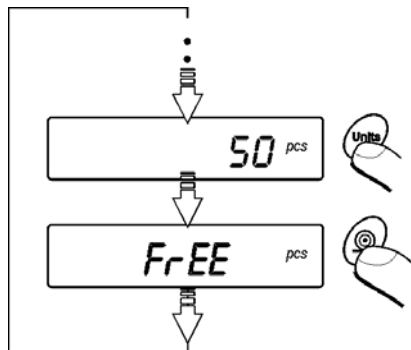

- set up batch quantity by means of keys **ON/OFF** – choose digit



Units – choose value

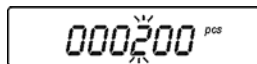

- confirm by pressing key **PRINT** -
LOAD appears on display

LOAD



- after making sure that batch with declared quantity is put on scale confirm by key **PRINT** once again - balance displays **Process**, and then amount of elements and **PCS**.

~ 200 pcs



- after adding or take counted elements off scale their amount appear on display

Return to weighing mode

- press key **Units** many times until - **PIECES** appears on display

PIECES

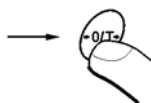

- press **ZERO/TARE** key

Balance return to weighing mode and diode with **g** mark starts flashing

~ 29.00 g

Attention:

- If you choose batch quantity remember that precision of counting depends on metrological parameters of balance and on repeatability of mass singular counted elements.
- Result of measurement is more precise if batch quantity is bigger
- If summary mass of batch quantity is less than 5 reading divisions (5d) – balance shows order about error **-LO-** and return to weighing automatically.

8.2. Control of deviations % according to standard mass

Software enables control of deviations (in %) mass of weighed loads from standard mass. Standard mass can be defined by weighing (function **PERC A**) or written to balance memory by user (function **PERC B**)

8.2.1. Standard mass defined by its weighing

Procedure:

Press key **ZERO/TARE**. When horizontal lines appear on display press **Units**



- Press key **Units** many times until on display appear

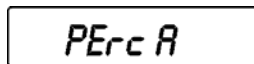

- press key **PRINT** to active function
- on display appears:

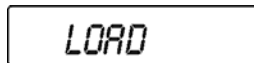

- put load on scale. Mass of this load is assumed as standard
- press **PRINT** to confirm this work mode
- on display appears **Process** and after few seconds **100,00%**

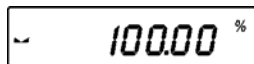

From this time instead of mass weighed load relation load on scale to standard mass is displayed. (in %).

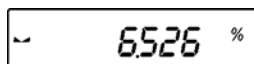

8.2.2. Standard mass introduced to balance memory by user

Procedure

Press key **ZERO/TARE**. When horizontal line appear on display press key **Units**

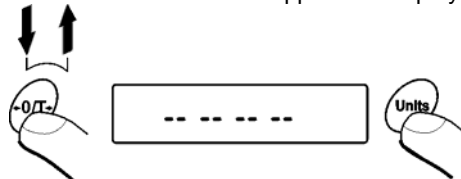

- Press key **Units** many times until - **PERC B**
- Appears on display

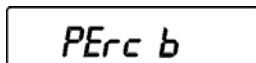

- press **PRINT** key to activate this function
- Appears on display



- by means of keys:

ON/OFF – choose digit,

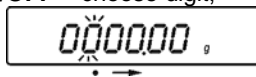

Units - choose value of digit

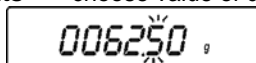

set value of standard mass and write it in balance memory by means of key **PRINT** – on display appears: **0,00 %**

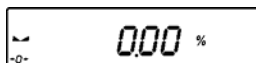

From this time relation of load on scale to standard mass (in%) is displayed instead of weighed load mass. Leave mode of percentage deviations from standard mass control. **Return to weighing:** press key **ZERO/TARE**. When horizontal lines appear on display press **Units**. Press key Units many times until Perc A or Perc B appears on display - press **ZERO/TARE**,

8.3. Definition thickness of solids and liquids

There is equipment to defining thickness of solids and liquids in additional equipment.

8.3.1. Testing thickness solids

Thickness of solids can be tested in one of 3 liquids:

- H₂O (distilled water),
- C₂H₅OH (spirit 100% +/- 0.1% in temp. 20⁰C),
- AnotHEr (another liquid with known thickness)

Give temperature of liquid for distilled water and spirit. For liquid with known thickness value is written on keyboard.

To test thickness weigh sample on upper scale and weigh the same sample in liquid (on down scale). Result is represented on display automatically after replacing sample in liquid.

8.3.2. Testing thickness of liquid

Basic element for measuring thickness of liquid is glass plunger. It has precise capacity shown on hook.

Before final measurements this value should be introduced to scale memory. To test thickness of liquid weigh glass plunger on upper scale and in tested liquid. Result of testing is shown on display automatically after introducing mass of plunger.

9. Adjusting the balance to working conditions

- Back light function
- Turn off/on system of autozero
- Turn off / on automatic calibration in relation to changes of temperature
- Turn off/ on automatic calibration in relation to time from last calibration
- Setting amount of average measurements
- Average result of weighing
- Adjusting balance for dosage procedure
- Select default units of weighing

Press **ZERO/TARE** key (scale shouldn't display STAB). If horizontal lines appears on display press key **CAL**

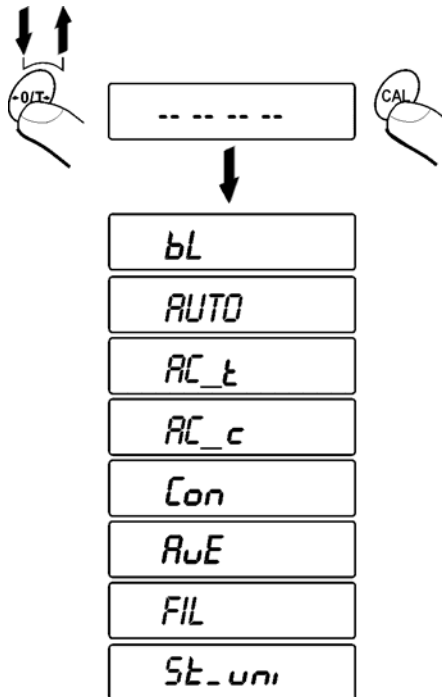

After pressing key **Units** name of first approachable function appears. Every next pressing key **Units** makes names of following approachable functions appear on display. Way of setting functions is described in further part of instruction.

9.1. Back light

Press key **ZERO/TARE**. When horizontal lines appears on display press key **CAL**.
Display shows:

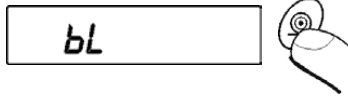

- Press **PRINT** key – display shows actual value for this function
- Press key **Units** many times and set value on 0 or 1 including following dependences

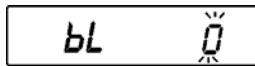

bl **0** – back light is turn **OFF**

bl **1** – back light is turn **ON**

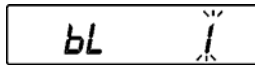

- Press key **PRINT** to confirm setting.



9.2. Turn on/off autozero system

Press key **ZERO/TARE**. When horizontal lines appears on display press key **CAL**. Then press key **Units** many times until order **AUTO** appears on display. Press key **PRINT**

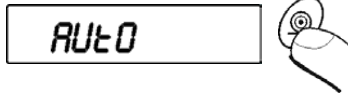

- Current value for autozero function appears on display.

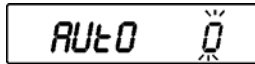

- Press key **Units** many times and set value on 0 or 1 including following dependences:

AUTO 0 - autozero is turn **ON**

AUTO 1 - autozero is turn **OFF**

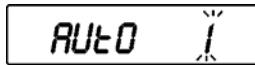

- Press key **PRINT** to confirm setting.



Notice: Remember that setting **AUTO 1** (autozero is turn off) refers to possibility of not stable result for not loaded scale.



9.3. Calibration - settings

See description in points:

- 7.2.1.1 (calibration dependently on temperature - parameter <AC_t>)
- 7.2.1.2. (calibration dependently on time - parameter <AC_C>)

9.4. Choice of criteria of stable result depending on conditions of using

Press key **ZERO/TARE**. When horizontal lines appears on display press key **Units**. Then press **Units** key many times until order **Con** appears on display

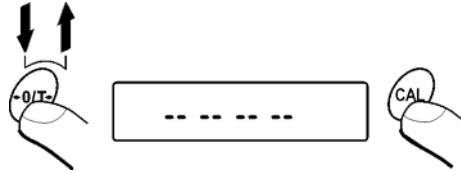

- Press **PRINT** key. Next to **Con** settled value of parameter with flashing number is displayed. Flashing number means stage of average result

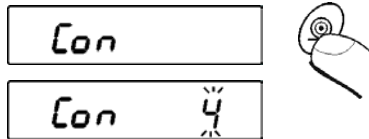

- By pressing key **Units** change value of flashing number choosing one of the stages of averaging.

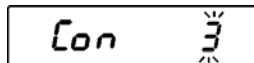

- Press **PRINT** key to confirm setting



If the conditions of work are good value **Con** should be settled on level 1÷2.
If the conditions are worse (drafts, breeze of air) set value on 5.

Notice:

*If user increases this parameter time of waiting for stable result is longer. If the conditions of work are bad and value **Con** are big scale cannot get stable result. But if value **Con** is too low for bad conditions scale doesn't get stable result (**STAB** lights on and off on display).*

9.5. Average result of weighing

In various applications result of measurement is presented as average value of several measurements especially if the conditions are not stable (vibrations, twitches). In these cases if you use higher stage of the digital filter the measurement is done with the established precision.

Press the **ZERO/TARE** button, when horizontal lines appear on the display press the **CAL** button.



- The balance shows first function in the menu. Press the **Units** key repeatedly until command **AuE** appears on the display.
- Press the **PRINT** button

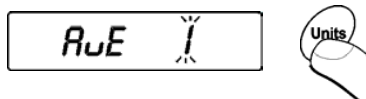
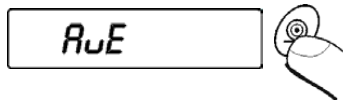

- Pressing the **Units** button set up new value of the function **AuE** with complying following conditions:

- AuE - 1** – average result I stage
- AuE - 2** – average result II stage
- AuE - 3** – average result III stage

- Confirm chosen value by pressing the **PRINT** button



9.6. Adjusting scale for dosage procedures

During dosage substances essential matter is fast reaction of the balance on mass increment. During this process digital filters must be turn off because they make reaction time longer although they help if any disturbances occur.

Press the **ZERO/TARE** button, when horizontal lines appear on the display press the **CAL** button

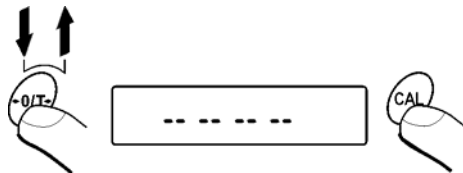

- The balance shows first function in the menu. Press the **Units** key repeatedly until command **FIL** appears on the display.
- Press the **PRINT** button

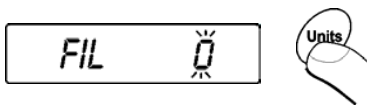
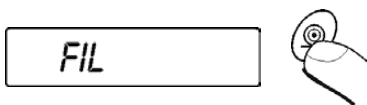

- Pressing the **Units** button sets up new value of the function **FIL** but comply with following conditions:

FIL	0	– understood value of the digital filters (recommended for weighing process)
FIL	1	– recommended for dosage, pouring, filling etc.

- Confirm chosen value by pressing the **PRINT** button



Attention:

In the menu there is also function AUTO (autozero). This function controls zero point of the scales. User can turn it off before the dosage. The procedure of turn autozero off is included in the instruction manual.

9.7. Select default unit of weighing

Press the **ZERO/TARE** button, when horizontal lines appear on the display press the **CAL** button

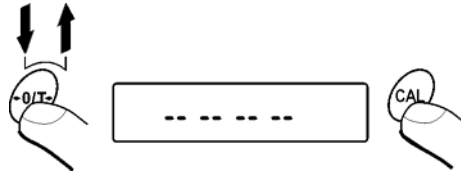

The balance shows first function in the menu. Press the **Units** key repeatedly until command **St_uni** appears on the display.

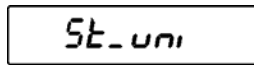

Press **PRINT** button many times. The display will show units.

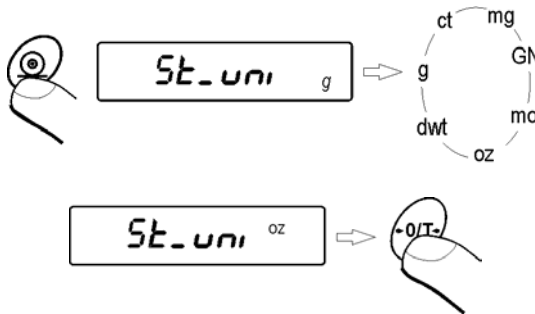

Press **ZERO/TARE** key to confirm selected units.

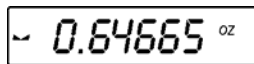

ATTENTION:

Default units will be show after switch on the balance.

10. FUNCTIONS FOR USING RS 232

- Choose speed of transmission
- Define sent data as: stable / not stable
- Continuous work
- Setting data as additional element of parameter in printouts
- Turn on/off sign of last digit in printout
- automatic operating for RS 232

Press **ZERO/TARE** key. When horizontal lines appear on display press key **PRINT**.

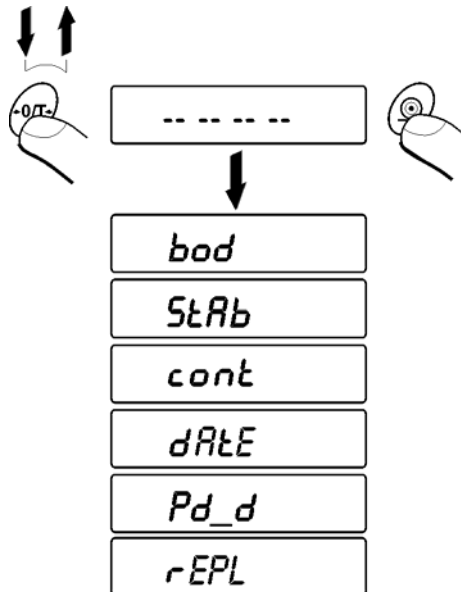

After pressing **PRINT** name of first approachable function appears. Every pressing of key **Units** makes names of following approachable functions appear on the display. Way of setting functions is described in further part of instruction.

10.1. Choice of speed of transmission

Press key **ZERO/TARE**. When horizontal lines appear on display press key **PRINT**.

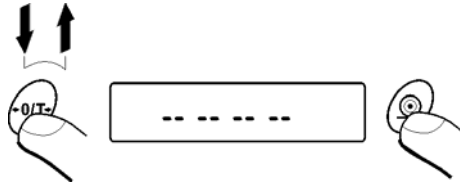

Then press key **Units** until order **bod** appears on display. Press key **PRINT**.

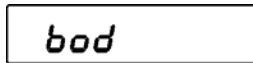

- Press **PRINT** key (display shows value for function BOD)

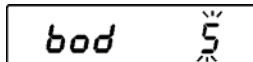

- press **Units** key many times until number of speed of transmission appears as below:



bod 1	- 300 bit / s,
bod 2	- 600 bit / s,
bod 3	- 1200 bit / s,
bod 4	- 2400 bit / s,
bod 5	- 4800 bit / s,
bod 6	- 9600 bit / s,

- confirm by pressing **PRINT**.



10.2. Definite send data as stable/not stable

Press key **ZERO/TARE**. When horizontal lines appear on display press key **PRINT**

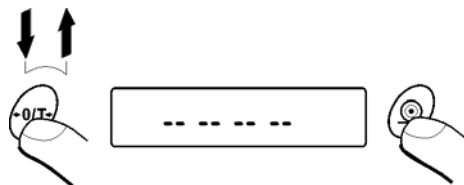

- Then press key **Units** many times until order **StAb** appears on display.



StAb

- by means of **PRINT** key start programming functions



StAb 0

- by key **Units** choose one of two values



STAB 0 – sending stable result of weighing
STAB 1 - sending temporary result of weighing

- confirm by pressing **PRINT**.



10.3. Continuous work (RS 232)

Press key **ZERO/TARE**. When horizontal lines appear on display press key **PRINT**.



- Then press key **Units** many times until order **cont** appears on display.

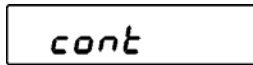

- Press key **PRINT**, current value appears on display

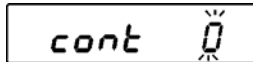

- by key **Units** choose one of two values

CONT 0 - lack of constance transmission
CONT 1 - constant transmission



- confirm by key **PRINT**



10.4. Set-up date as basic parameter of printout

Signal (equivalent for state of display) is sent to printer by scale has form:
+ 123.456 g <CR>< LF> (16 signs in general)

There is possibility of sending data in increased form f.eg.:

DATE 1998.09.21 TIME 09:51 + 100.001 g

Printing results of measurements in increased form is possible only with printer KAFKA 1/Z, KAFKA SQ S.

Press key **ZERO/TARE**. When horizontal lines appear on display press key **PRINT**.

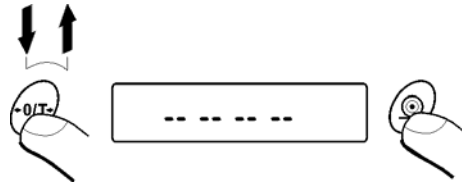

- Then press key **Units** many times until order **dAtE** appears on display.

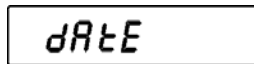

- By means of key **PRINT** start programming functions

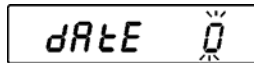

- by means of key **Units** choose one of two values
dAtE 0 – printing in standard format
dAtE 1 – printing in increased format

- confirm choice by key **PRINT**

10.5. Turning on and off marker of last digit on printouts

Press key **ZERO/TARE**. When horizontal lines appears on display press key **PRINT**.



- Then press **Units** many times until **Pd_d** appears on display.
- Press key **PRINT**.

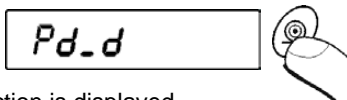

- Current value for function is displayed.

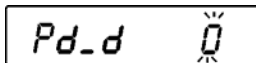

- Press key **Units** and change value 0 or 1 with consideration following dependences:

Pd_d 0 – marker of last number is switched **ON**

Pd_d 1 - marker of last number is switched **OFF**

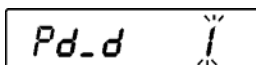

- Press key **PRINT** to confirm chosen set-up.



After setting-up parameter **Pd_d** on value **1** after press key **PRINT** indication with last number of weighing result (brackets) is printed. Before start cooperation balance-computer set value for function **Pd_d** as:

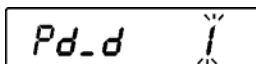

Attention:

Pd_d function is available only for not verified balances

10.6. Automatic work for RS 232

Press key **ZERO/TARE**. When horizontal lines appears on display press key **PRINT**.



- Then press **Units** many times until **rEPl** appears on display.
- Press key **PRINT**.

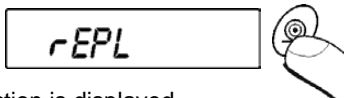

- Current value for function is displayed.

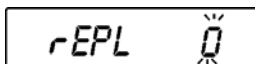

- Press key **Units** and change value 0 or 1 with consideration following dependences:

REPL 0 – manual operating / after pressing **PRINT** key/

REPL 1 – automatic operating / when result of weighing is stable/

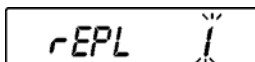

- Press key **PRINT** to confirm chosen set-up.

Automatic operating proceeds according to following scheme:

- press TARE key to zero the scale (display will indicate marker of stable measurement and zero marker)
- place the load, balance will send through RS 232 first stable result
- remove load from the pan
- next measurement will be possible, when result of weighing is +/- 50 reading units referring to zero (by next measurement zero state is not required).

11. COOPERATION WITH PRINTER OR COMPUTER

Every pressing of key < **PRINT** > makes sending signal of current state of display with measure units to computer or printer. Scale has factory settled speed of transmission 4800 bit/s. If external mechanism (printer, computer) need to have settled different speed of transmission change factory setting about speed in menu (parameter **bod**)

11.1. Schedules of connecting conductors

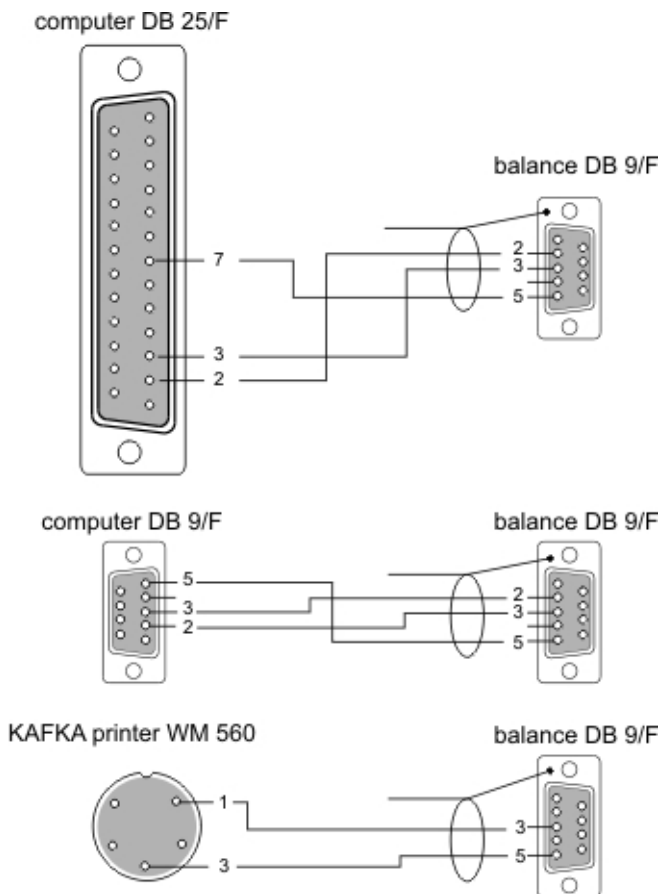

11.2. Printing data with date and time

Every printout of weighing can be printed with date and time of measurement. It's possible if scale is connected to printer **Kafka 1/Z** or **Kafka SQ S**.

After connecting scale and printer set value of parameter **DATE** as:

DATE 1

(see Setting date as additional parameter for printout)

11.3. Cooperation with statistic printout Kafka SQS

After connecting scale to printer **KAFKA SQ S** statistic of measurement is possible to do. Example of printout with statistics from series of measurement:

1	9:02:15	+ 7.0016	g
2	9:02:39	+ 5.0152	g
3	9:02:58	+ 12.0171	g
4	9:03:15	+ 9.9937	g
5	9:03:34	+ 12.0169	g
6	9:03:48	+ 22.0111	g

Data 13.09.2001 Godz. 9:04

<i>n</i>	6		<i>batch quantity</i>
<i>sum x</i>	68.0556	g	<i>summary of mass of samples</i>
\bar{x}	11.34260	g	<i>average value</i>
<i>s</i>	5.92328 g		<i>standard deviation</i>
<i>srel</i>	52.22	%	<i>factor of variancy</i>
<i>min</i>	5.0152	g	<i>min value</i>
<i>max</i>	22.0111	g	<i>max value</i>
<i>R</i>	16.9959	g	<i>difference max – min</i>

11.4. Format of sending data

Result of weighing can be sent from balance to external device after pressing the PRINT button on the balance or after sending order from the computer. Presented formats are conformable to settled parameter Pd_d = 1 (printout without last digit) for balances.

Give any result of weighing

1	2	3	4
S	I	C _R	L _F

Reaction of the balance for 0.0000 state

1	2	3	4	5	6	7	8	9	10	11	12	13	14	15	16	17	18	19	20	21
S	I	┐	┐	┐	+	┐	┐	┐	┐	0	.	0	0	0	┐	┐	g	┐	C _R	L _F

Reaction of the balance for 45.288g state

1	2	3	4	5	6	7	8	9	10	11	12	13	14	15	16	17	18	19	20	21
S	I	┐	┐	┐	+	┐	┐	┐	4	5	.	2	8	8	┐	┐	g	┐	C _R	L _F

12. Reports from scale

Scales with internal calibration can control parameters remembered in memory very quickly. Their function can be increased. Their service functions can be done easily.

12.1. Current control of calibration fault

Described function is useful if during long measurement user wants to be sure that results don't have bigger errors than error shown on display.

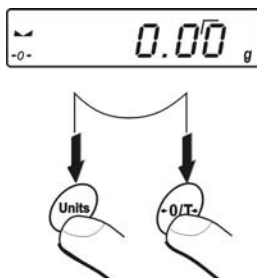

When scale is in autozero zone (ZERO) press keys **ZERO/TARE** and **Units** at the same time. Scale takes calibration mass and compares result of weighing with declared value of calibration mass. Difference between these two sizes is shown on digital display. Press **ZERO/TARE** key – return to weighing.

12.2. Report from calibration of scale

- Connect printer with real time clock to scale (**KAFKA 1/Z**)
- Press keys **ZERO/TARE** and **CAL** at the same time

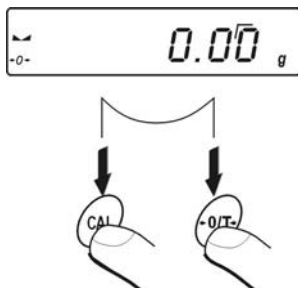

- Procedure of calibration

Example of report:

DATA 2003. 30.31
GODZ. 10:34

FACTORY NUMBER	0103985
PROGRAM NUMBER	LSE-761
CALIBRATION MASS	167.7214 g
MEASURED MASS	167.7213 g
DIFFERENCE MASS	- 0.0001 g

SIGNATURE

- **Procedure of calibration (balances with external calibration)**
 - Balance starts autotest for reports.
 - Display shows calibration mass
 - Put the load on the pan.
 - Balance is in auto adjusting mode
 - When adjusting is finished, remove load from the pan
 - Display show communicate: report
 - At the moment display show calibration mass
 - Put the load on the pan.
 - Report of the calibration is printing

Described function is useful when it's necessary to make documentation of controlling procedures.

13. WEIGHING LOADS UNDER SCALE

In standard analytical and precision balances can weigh load on suspension.

To use this function:

- Remove plastic plug in basic of scale
- There is suspension in the basic of scale. It's installed for good.
- Install hook to hang load (hook isn't standard equipment for scale), weigh load on hook.

Attention:

- Suspension cannot be turned around, move or manipulate. Mechanism of scale can be damaged this way.
- Mass all additional elements as scale, string should be settled to zero by pressing key **ZERO/TARE**.

14. LIST OF ORDERS COMPUTER – SCALE

Function Format	TARA – equivalent for key ZERO/TARE T CR LF (ZERO/TARE scale)
Function Format	PRINT (equivalent for key PRINT) S I CR LF (sending stage of display)
Function Format	CONSTANCE WORK - equivalent for key cont 1 C 1 CR LF (start constance transmission)
Function Format	MANUAL WORK – equivalent for order cont 0 C 0 CR LF (To change work mode on manual printout)
Function Format	STABLE DATA –equivalent for order STAB 0 S 0 CR LF (setting data to printout as stable)
Function Format	NOT STABLE DATA – equivalent for order STAB1 S 1 CR LF (setting data to printout as stable and not stable)

Attention!

*Sending order which is not in list or with error with end CR LF to scale makes return sending order in format **E S CR LF**. Spaces given in formats should be omitted. They are for better legible.*

15. ORDERS ON DIGITAL DISPLAY

Err- 5	- signalling terror of temperature converter, to start scale once again turn on and off power supply
FuLL – 1	- over crossed range of converter A/D
FuLL- 2	- over crossed range of weighing
nuLL	- too small load of scale (f.g. lack of scale)
tEst	- autotest of scale is done (after turn power on)
CAL	- calibration is done
DATE	- printing data with date and time
CONT	- constance transmission
AUTO	- turn on/off autozero
- Co -	- choose kind of work (checking thickness of solids)
- Li -	- choose kind of work (checking thickness of liquids)
Te_L 00	- order to write temperature (during checking thickness)
H2O	- distilled water (thickness of solids)
C2H5OH	- alcohol – spirit (thickness of solids) Spirit 100% +/- 0.1% in temp. 20 ⁰ C
AnotHER	- another liquid with known thickness (thickness of solids)
VOLUME	- order to write in value of capacity of plunger (checking thickness of liquids)
LoAD A	-order to put sample on upper scale (checking thickness)
LoAD L	- order to put sample on down scale (checking thickness)
Err-3	- too mach difference between start mass and settled factory mass and real start mass of scale – there is possibility to appears bigger errors
CAL Err	- error in calibration (calibrate scale once again)
bod	- function of setting speed of transmission
AC_t	- automatic calibration of scale
St_uni	- select default units of weighing
bl	- backlight function
repl	- automatic work

16. TECHNICAL PARAMETERS

	WPP 6/C	WPP 10/C	WPP 12/C10	WPP 25/C
	WPP 6/C/2	WPP 10/C/2	-----	WPP 25/C/2
Max. capacity	6 kg	10 kg	12 kg	25 kg
Readability	0,01 g	0,01 g	0,1 g	0,1 g
Tare range	-6 kg	-10 kg	-12 kg	-25 kg
Repeatability	0,01 g	0,01 g	0,1 g	0,1 g
Linearity	±0,02 g	±0,02 g	±0,1 g	±0,1 g
Pan size	250×300 mm		285×365 mm	
Operat. Temp	+15° - +40° C			
Weighing time	ok. 3 sekund			
Power	230V 50 Hz / 8VA			
Calibration weight – for version C or C10	5kg			10kg
Display	LCD			

Attention:

Balances marked with C/1 have system of external calibration and marked with C/2 have system of internal calibration.

17. ADDITIONAL EQUIPMENT

17.1. Vibration damping table



Thank's to this stable base all vibrations are eliminated. Inside of table marble plate is installed which makes foundation for balance.

17.2. Additional display



Characterization: Length of conductor between additional display and balance – 1,5m, plastic casing, possibility of bending the display

17.3. Computer softwares

- POMIARWIN – gathering data from any balance made by RADWAG.
- RADKEY – enables to introduce result of weighing to Exel.
- RECEPTURY – making mixtures. It has its own programmed contents base according to recipes are made.

*Instruction number:
LMI-14-01/09/06/A*

MANUFACTURER
OF ELECTRONIC WEIGHING INSTRUMENTS



RADWAG 26 – 600 Radom
Bracka 28 Street
POLAND

Central phone +48 48 38 48 800
phone/fax. + 48 48 385 00 10
Sales Department + 48 48 366 80 06
www.radwag.com



DIN EN ISO 9001:2000
CERTYFIKAT Nr 71 100 C20E